

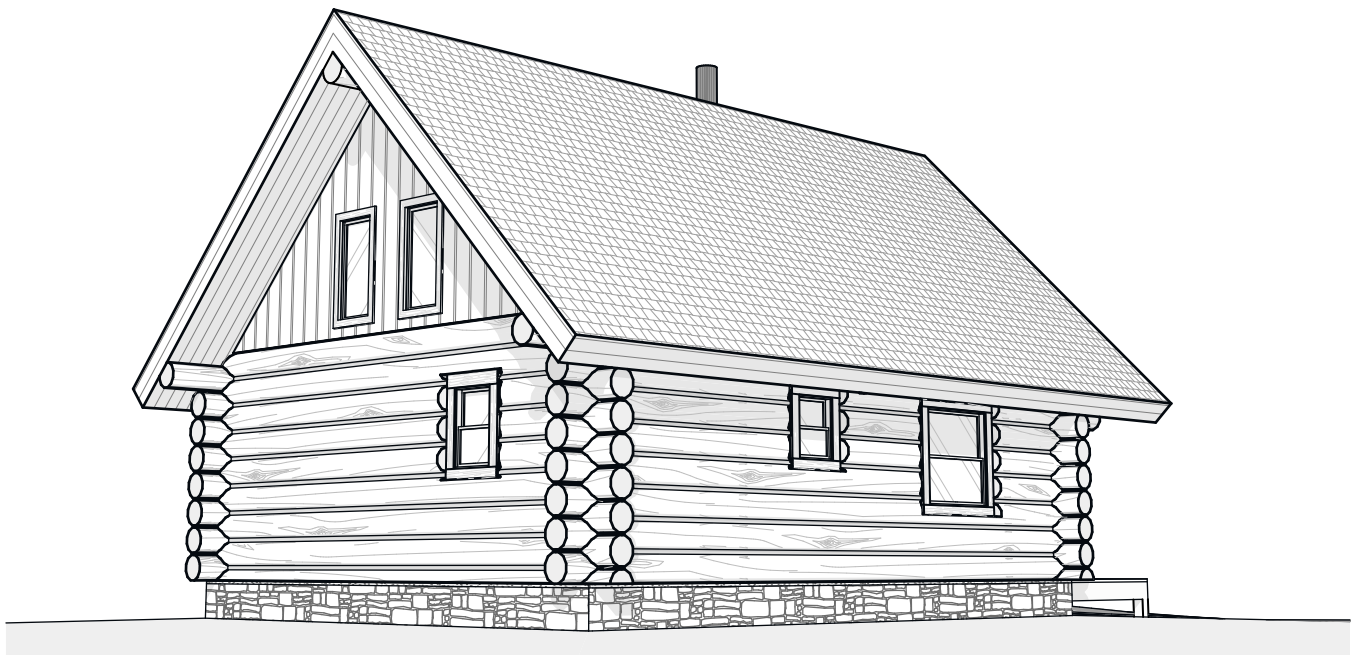

Woods Cabin



by CARIBOU CREEK



This plan set is conceptual in nature & not for construction. Its purpose is to serve as a basic schematic and visual representation only. All other uses prohibited. This plan is the intellectual property of Caribou Creek Log Homes.

Interior Square Footage

1. Main Floor	616
2. Second Floor	307
	923 ft ²

DESIGN: **Woods Cabin**
 Caribou Creek
 ADDRESS: 195 Sunrise Rd
 Bonners Ferry, ID
 PHONE: (800) 619-1156

LOG TYPE: Chink-Style
 LOG/TIMBER SIZE: 12" Ø
 EXTENSION STYLE: Straight
 DESIGN BY: Stuart Yoder
 REVISED: 5/17/2023



Woods Cabin

by CARIBOU CREEK

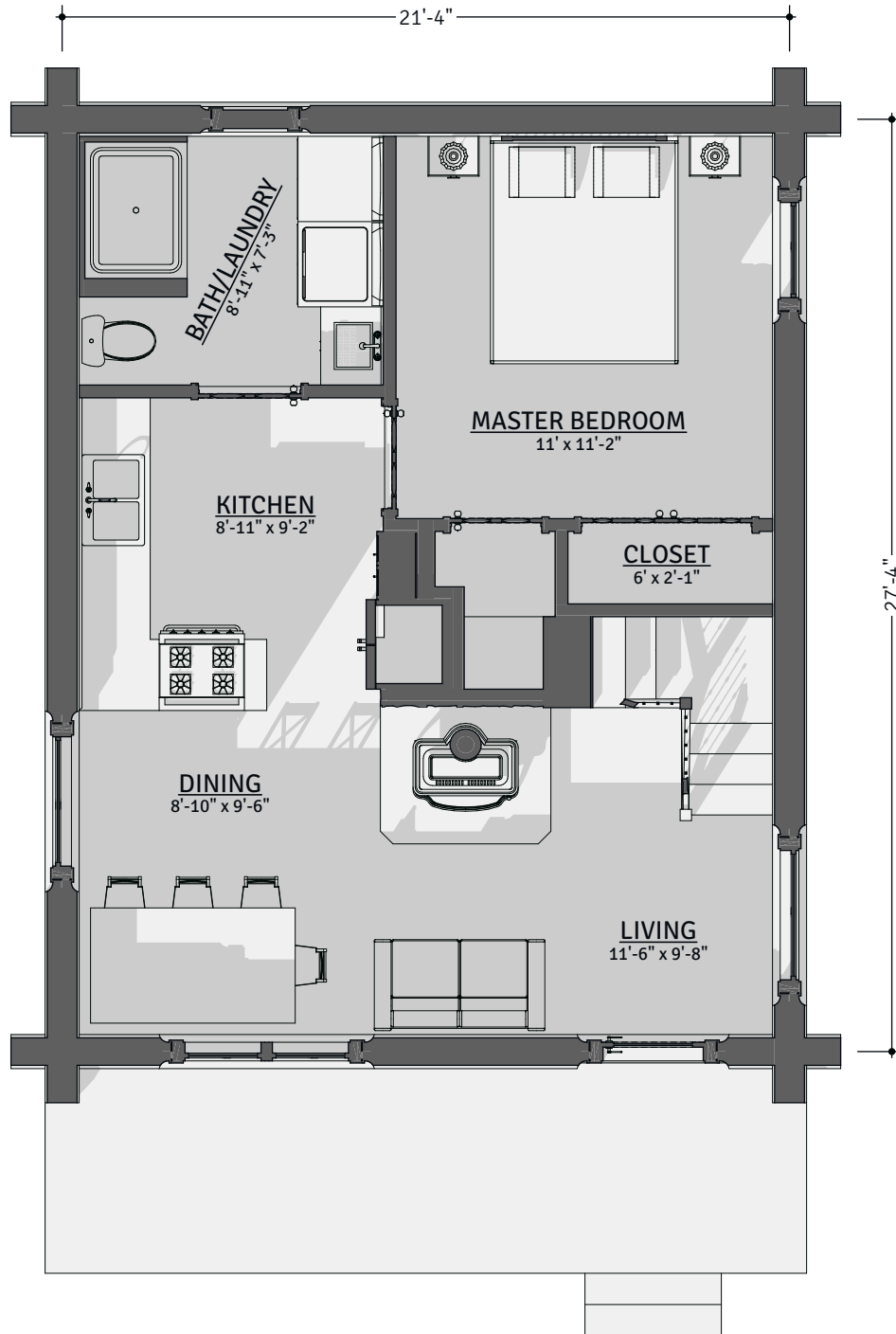

Main Floor Plan

CONCEPTUAL PLANS MAY NOT BE TO SCALE

This plan set is conceptual in nature & not for construction. Its purpose is to serve as a basic schematic and visual representation only. All other uses prohibited. This plan is the intellectual property of Caribou Creek Log Homes.



Woods Cabin

by CARIBOU CREEK

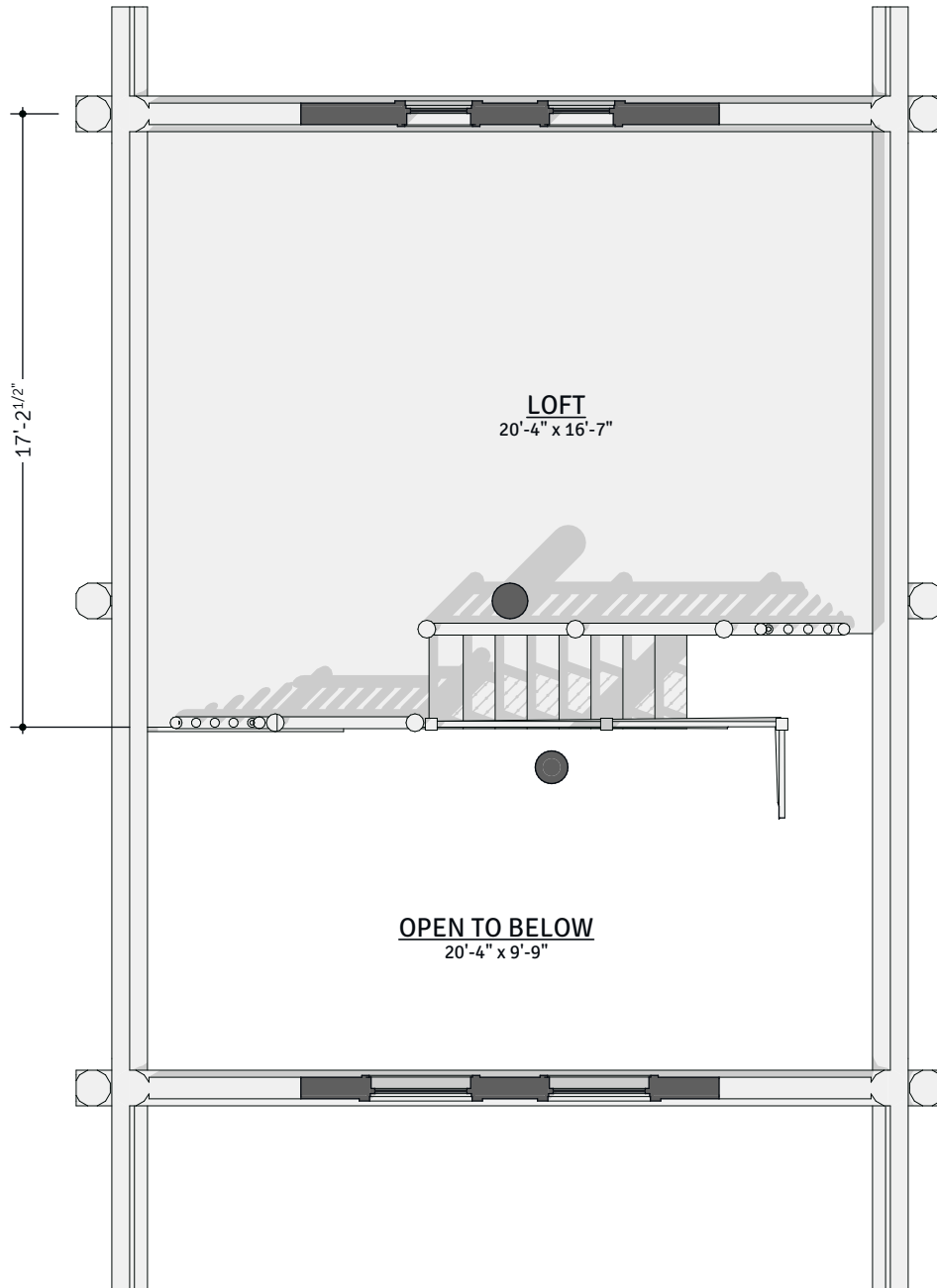

Second Floor Plan

CONCEPTUAL PLANS MAY NOT BE TO SCALE

This plan set is conceptual in nature & not for construction. Its purpose is to serve as a basic schematic and visual representation only. All other uses prohibited. This plan is the intellectual property of Caribou Creek Log Homes.



Woods Cabin

by CARIBOU CREEK

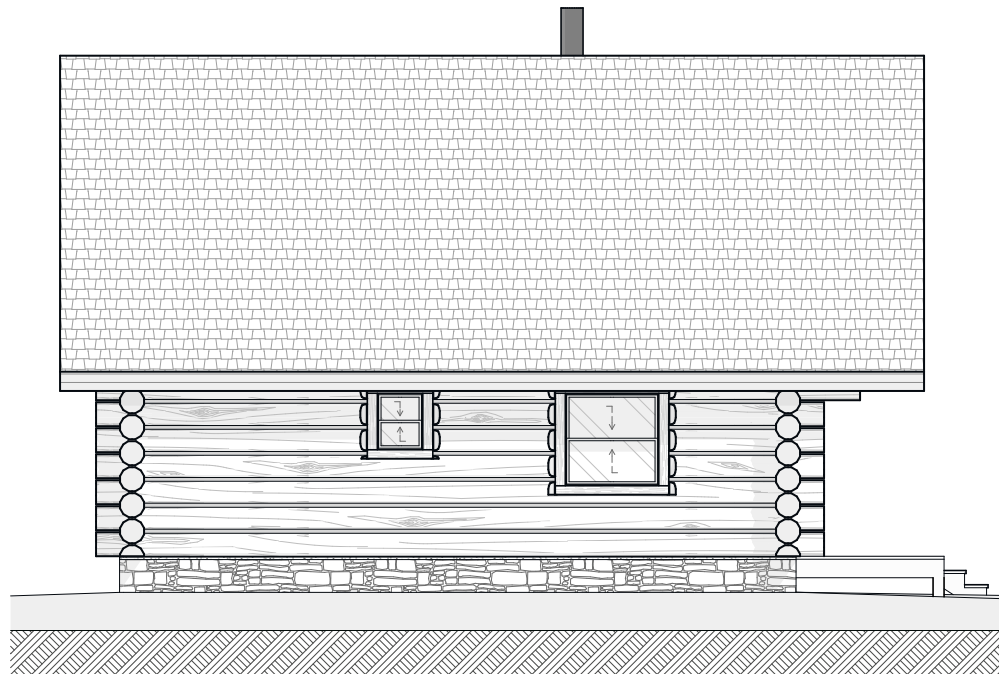
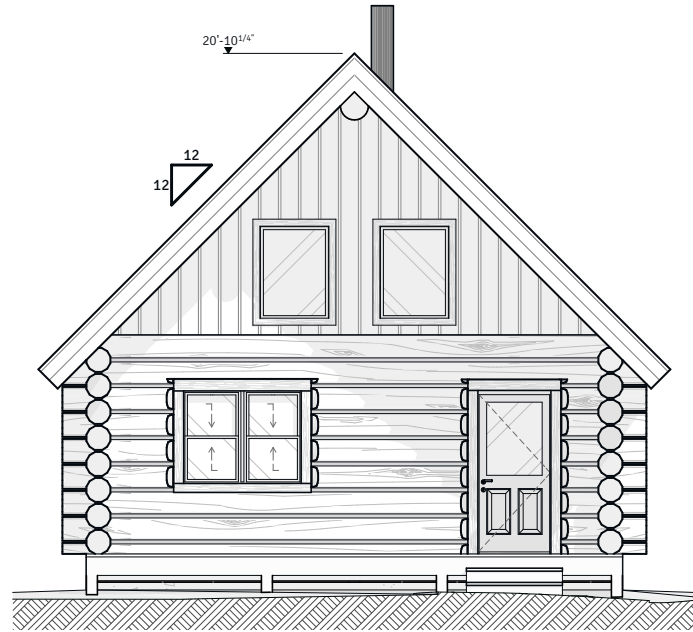

Front Elevation, Left Elevation

CONCEPTUAL PLANS MAY NOT BE TO SCALE

This plan set is conceptual in nature & not for construction. Its purpose is to serve as a basic schematic and visual representation only. All other uses prohibited. This plan is the intellectual property of Caribou Creek Log Homes.



Woods Cabin

by CARIBOU CREEK

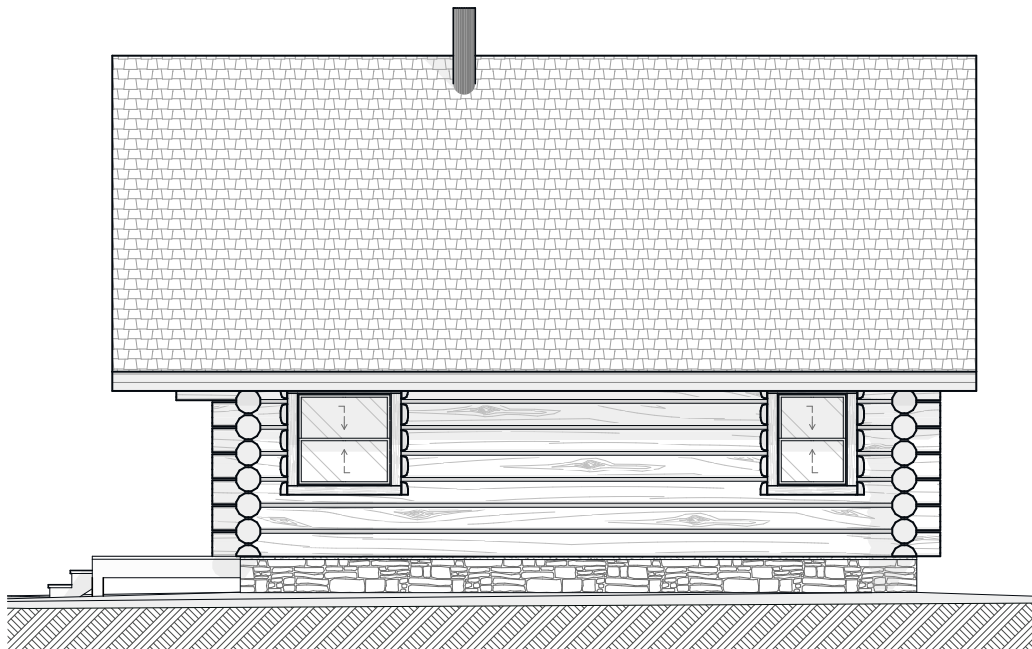
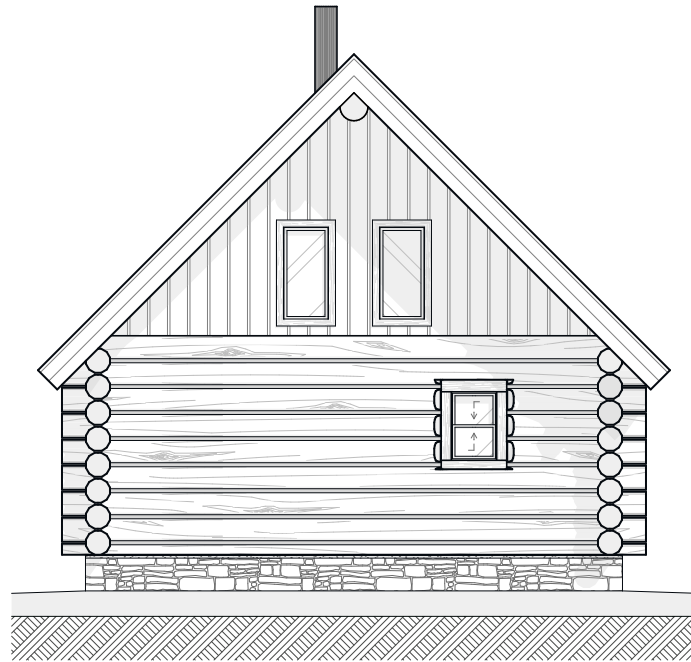

Rear Elevation, Right Elevation

CONCEPTUAL PLANS MAY NOT BE TO SCALE

This plan set is conceptual in nature & not for construction. Its purpose is to serve as a basic schematic and visual representation only. All other uses prohibited. This plan is the intellectual property of Caribou Creek Log Homes.



Woods Cabin

by CARIBOU CREEK

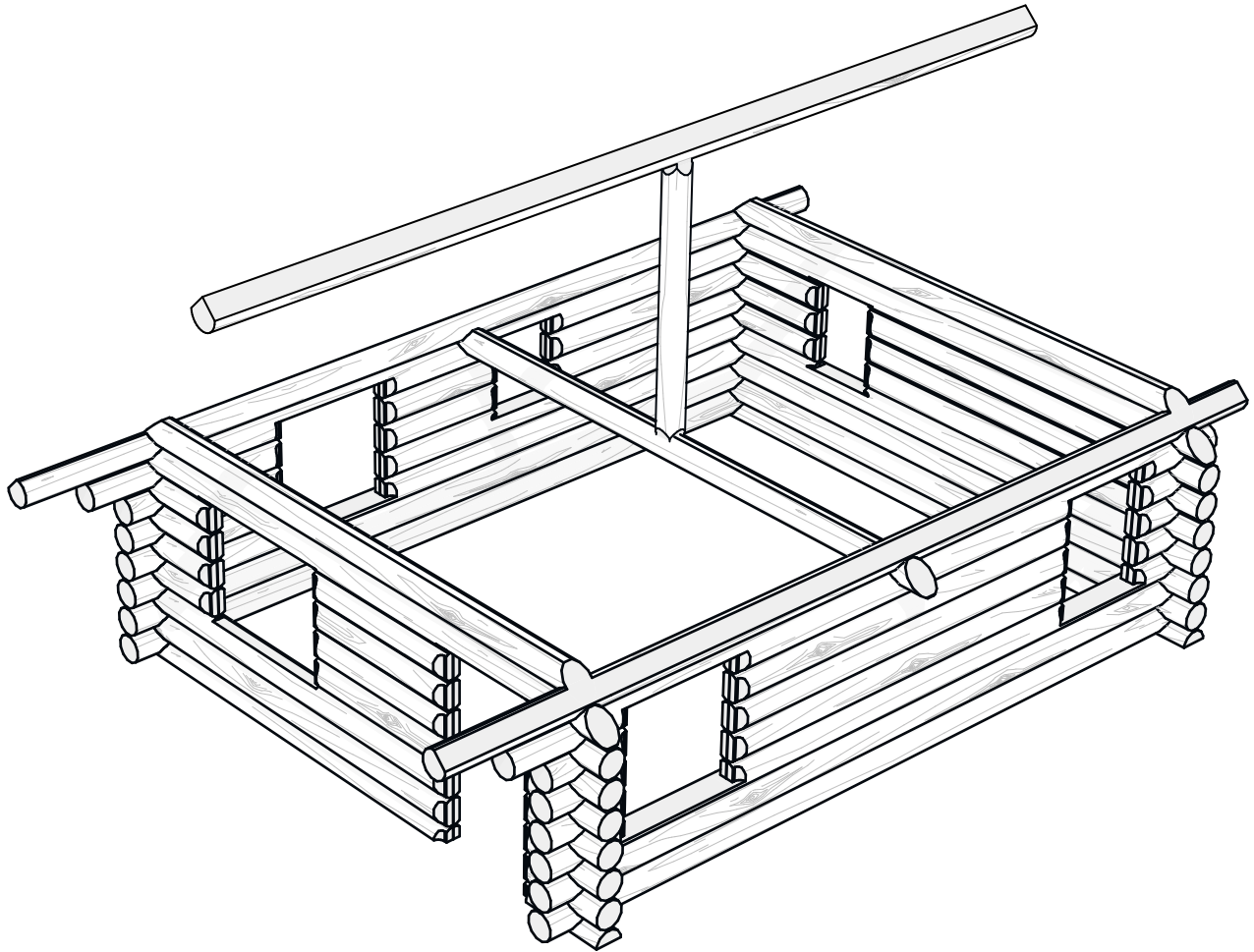

Log Package

CONCEPTUAL PLANS MAY NOT BE TO SCALE

This plan set is conceptual in nature & not for construction. Its purpose is to serve as a basic schematic and visual representation only. All other uses prohibited. This plan is the intellectual property of Caribou Creek Log Homes.