

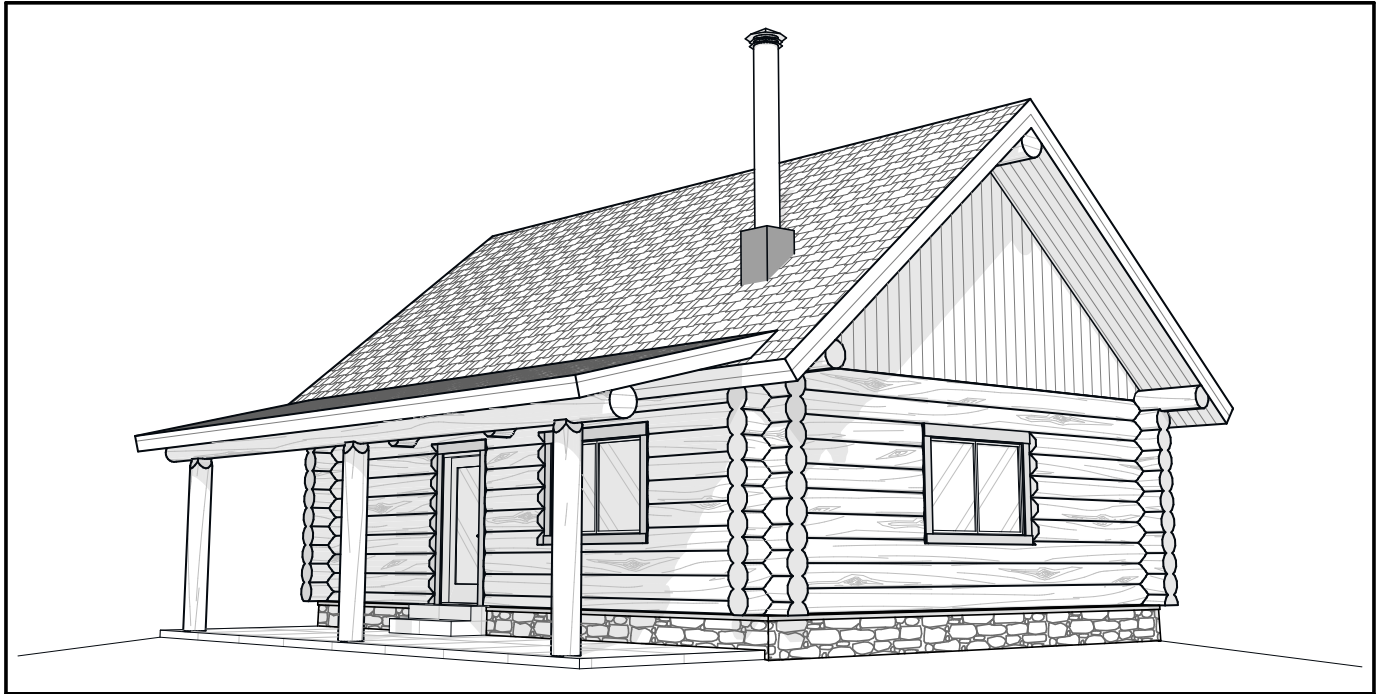

The Sportsman

by CARIBOU CREEK



This plan set is architectural in nature: intended to serve as a basic design, layout, and visual representation only. All construction details outside of the scope pertaining to Caribou Creek, required engineering, and compliance to local codes are the sole responsibility of the Client and Contractor. This plan is the intellectual property of the Client and Caribou Creek.

Interior Square Footage	
1. Main Floor	768
2. Loft	181
	949 ft ²

Project Name: The Sportsman
 Client Name: Caribou Creek
 Address: 195 Sunrise Rd
 Bonners Ferry, ID
 Phone: (800)619-1156

Project Location: Bonners Ferry, Idaho
 Contractor:
 Sales Manager:
 Drawn By: Stuart Yoder
 Publish Date: 3/27/2023



The Sportsman

by CARIBOU CREEK

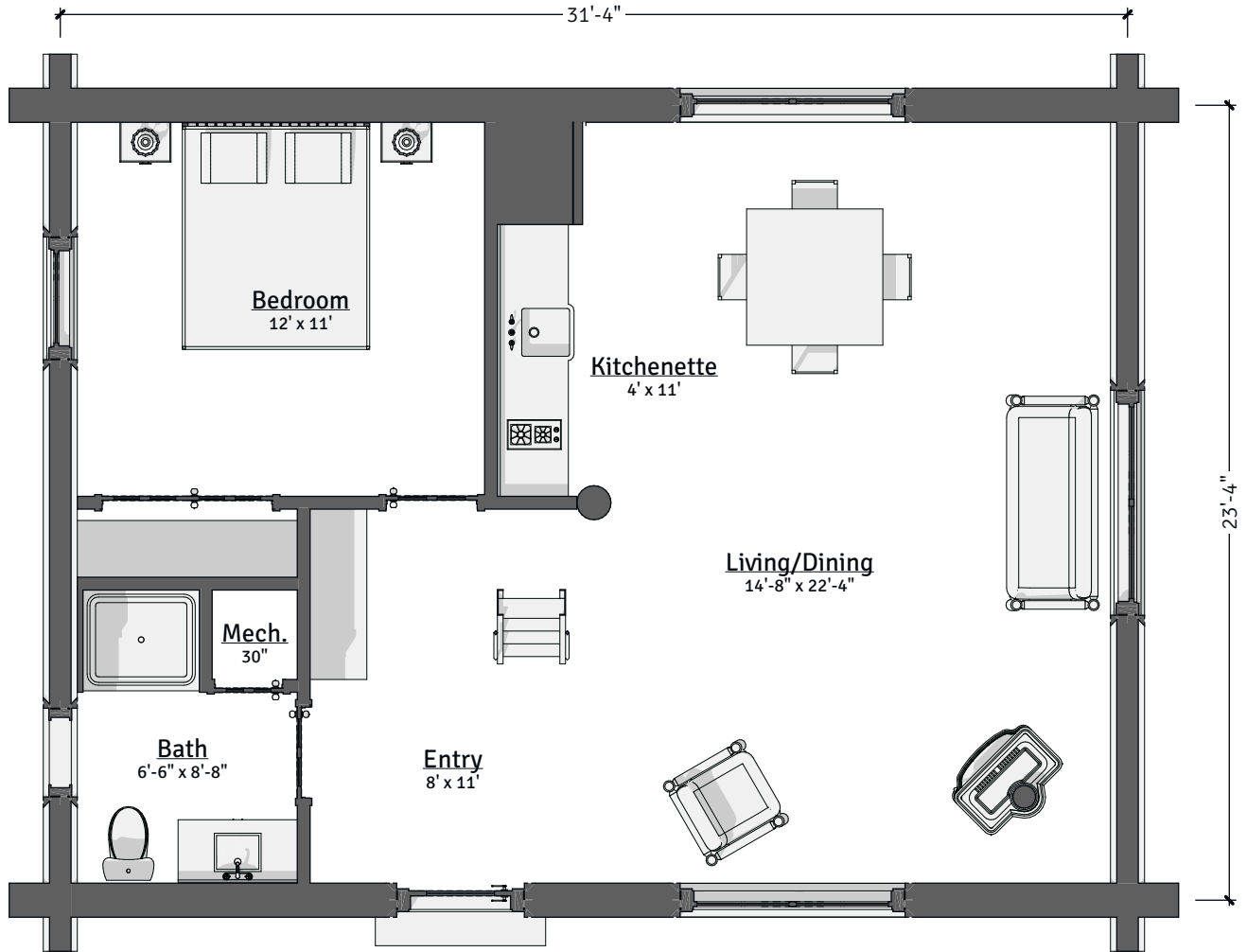

Main Floor: Finish (Sub+3/4")

CONCEPTUAL PLANS MAY NOT BE TO SCALE

This plan set is conceptual in nature & not for construction. Its purpose is to serve as a basic schematic and visual representation only. All other uses prohibited. This plan is the intellectual property of Caribou Creek Log Homes.



The Sportsman

by CARIBOU CREEK

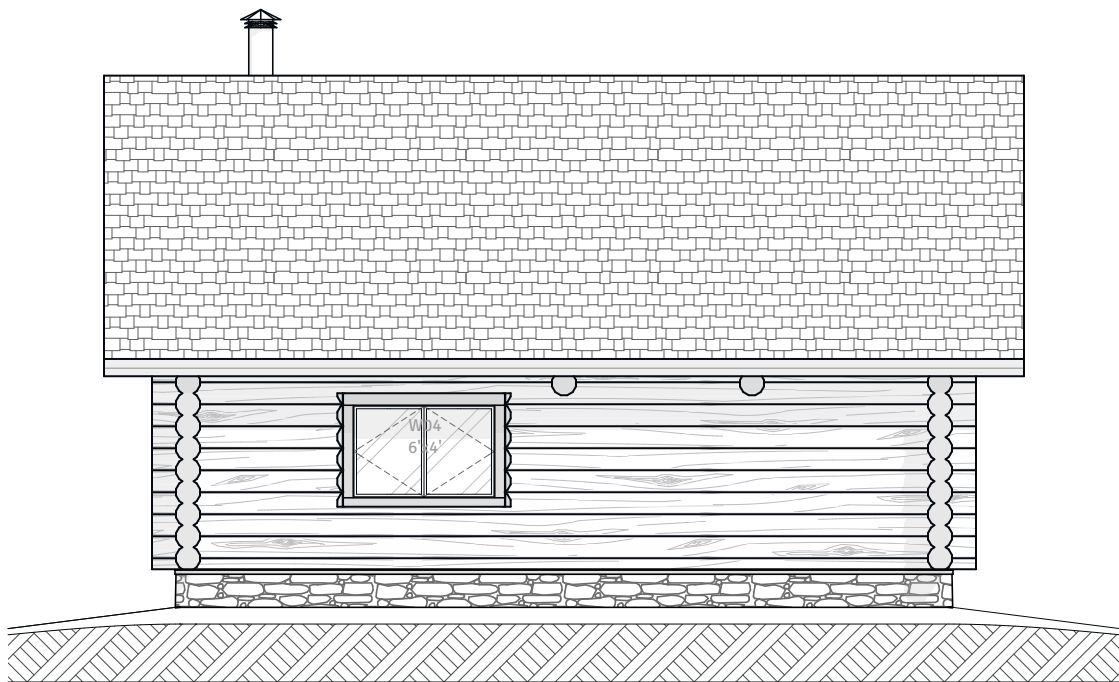
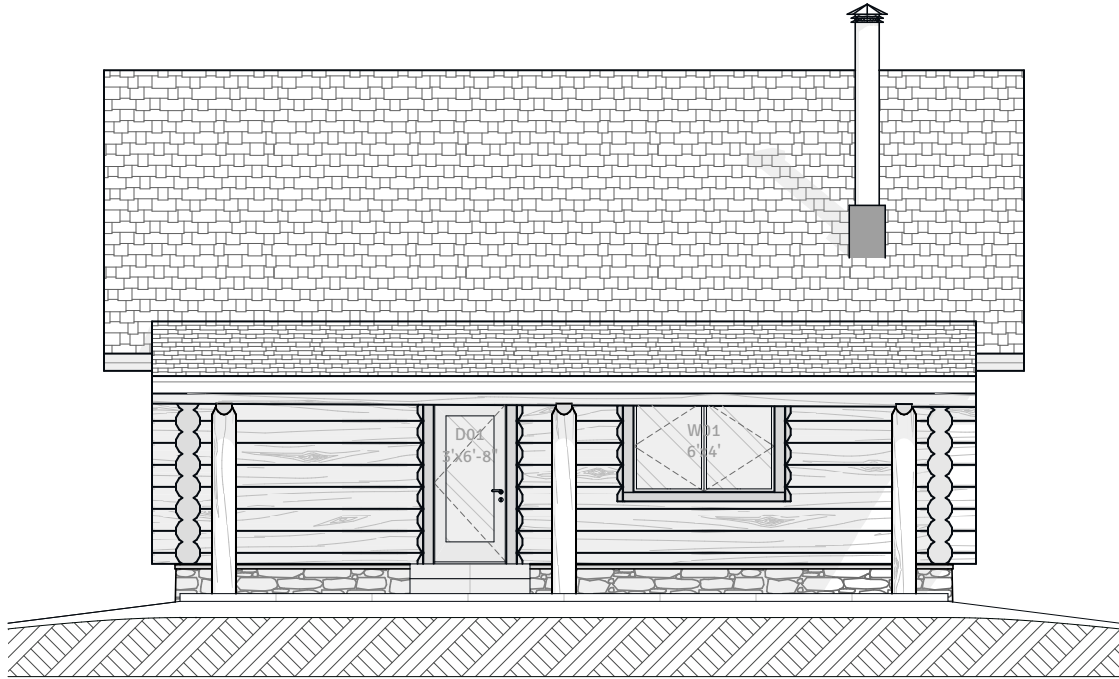

Rear Elevation, Front Elevation

CONCEPTUAL PLANS MAY NOT BE TO SCALE

This plan set is conceptual in nature & not for construction. Its purpose is to serve as a basic schematic and visual representation only. All other uses prohibited. This plan is the intellectual property of Caribou Creek Log Homes.



The Sportsman

by CARIBOU CREEK

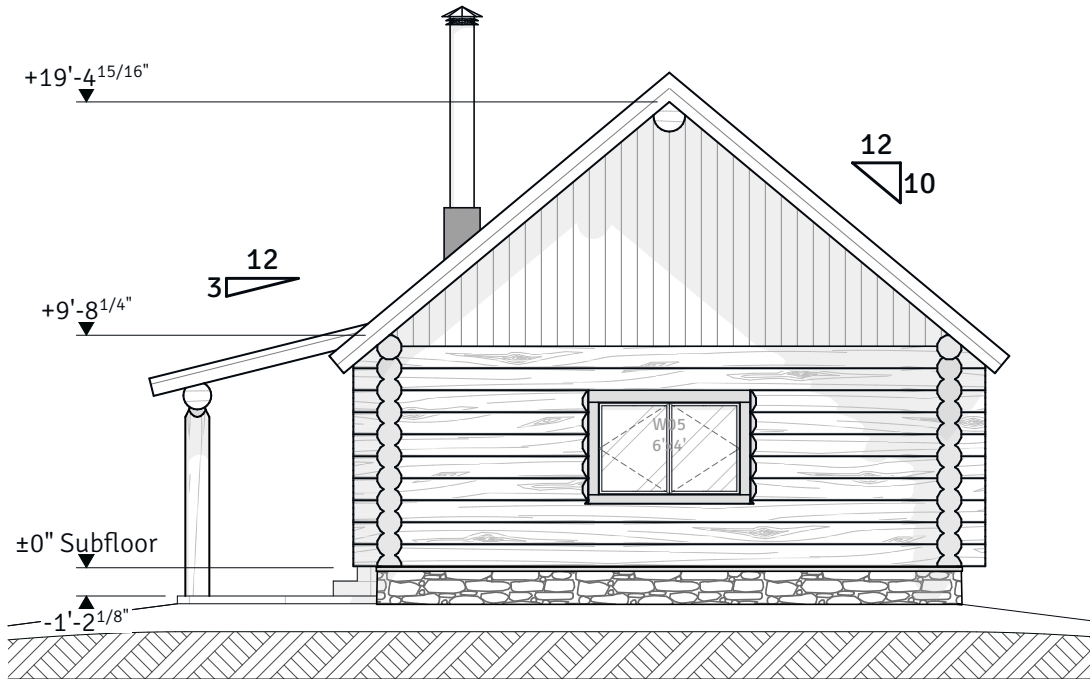

Left Elevation, Right Elevation

CONCEPTUAL PLANS MAY NOT BE TO SCALE

This plan set is conceptual in nature & not for construction. Its purpose is to serve as a basic schematic and visual representation only. All other uses prohibited. This plan is the intellectual property of Caribou Creek Log Homes.



The Sportsman

by CARIBOU CREEK

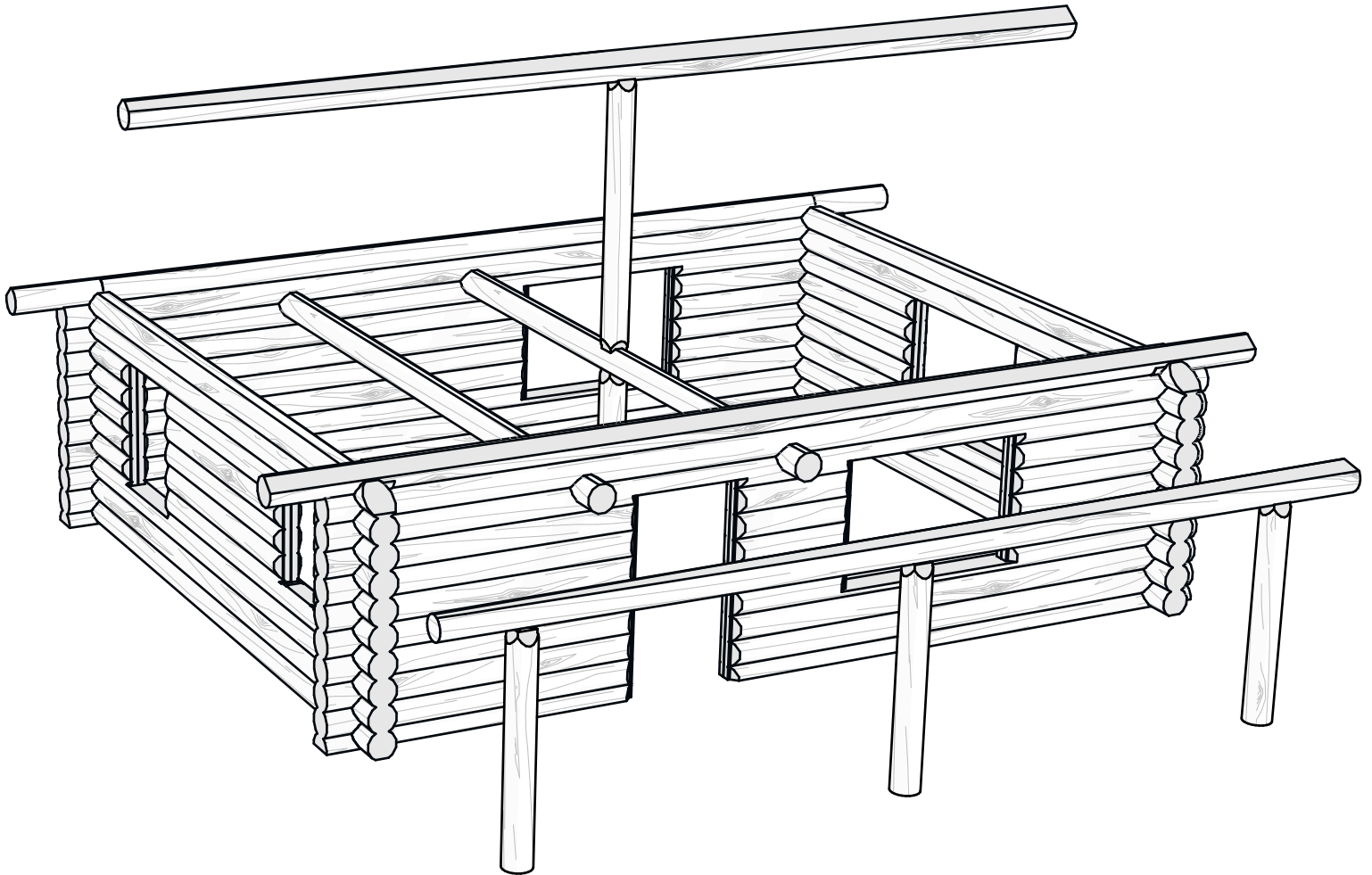

Log Package

CONCEPTUAL PLANS MAY NOT BE TO SCALE

This plan set is conceptual in nature & not for construction. Its purpose is to serve as a basic schematic and visual representation only. All other uses prohibited. This plan is the intellectual property of Caribou Creek Log Homes.